

The Smart Choice...

By Utostav

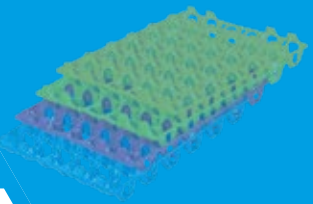

UTC STAV
FOR POULTRY PACKAGING & EQUIPMENT



**POULTRY
EQUIPMENT**
Product Catalogue

*The Smart
Choice...*



About Us

With over 20 years of experience in the poultry industry, we deliver complete, high-performance solutions designed to maximize efficiency, productivity, and profitability.

We provide a full range of advanced poultry equipment, including feeding and drinking systems, heating, ventilation, cooling, lighting, feed silos, feed transport systems, egg production systems, and smart computerized control technologies-all tailored to meet the demands of modern poultry operations.

From concept to completion, our expert team stands by your side. We support every stage of your investment-project design, system installation, and after-sales service-ensuring seamless execution and long-term reliability.

Our systems are trusted by customers both in Turkey and international markets, thanks to their superior quality, durability, and consistent performance. By combining premium materials with precise engineering and competitive pricing, we create real and sustainable value for our partners.

Driven by a young, dynamic, and innovation-focused team, we continuously push the boundaries of technology to bring you smarter, more efficient solutions.

Our promise is simple:

Reliable systems. Strong performance. Long-term partnership.

Mission

At Sistemtav, our mission is to deliver advanced, high-quality poultry technologies that enable our customers to achieve higher efficiency, profitability, and sustainable growth.

We are committed to:

- Creating continuous value for our customers, employees, partners, and society
- Operating with integrity, full compliance, and strong business ethics
- Delivering reliable, high-performance, and continuously evolving solutions
- Using resources efficiently and responsibly
- Fostering a culture of teamwork, development, and employee engagement
- Acting with strong environmental awareness and social responsibility
- Building long-term, value-driven partnerships with our suppliers
- Applying modern production and engineering technologies

By combining global innovation with local expertise, we empower Turkish poultry producers to compete more effectively in both domestic and international markets.

Vision

To become a globally recognized and trusted brand in poultry equipment systems, known for delivering sustainable growth, competitive strength, and long-term value to the industry.



Product Portfolio

Feeding Solutions (Pages 2–3)

Automatic Feeding Systems / Manual Feeding Equipment

Drinking Systems (Pages 4–7)

Regulators, Nipples and Drinkers

Cooling Systems (Pages 8–9)

PVC AQUA MAKER Cooling Solutions

Ventilation Equipment (Pages 12–13)

Exhaust Fans / Fan Shutters

Automation & Control Cabinets (Pages 14–15)

Advanced Climate Control

Ventilation Systems (Pages 16–17)

Weighing Systems (Pages 18–19)

Bird Weighing Systems / Feed Weighing Systems

Egg Production Systems (Pages 20–21)

Automatic & Manual Nests / Male Feeding Systems

Feeding Lines (Pages 22–23)

Chain Feeding Systems

Climate & Lighting (Pages 24–25)

Heating Systems / Poultry House Lighting

Accessories (Pages 26–27)

Transport & Handling Solutions (Pages 28–29)

Transport Crates / Egg Transport Equipment



BRL-01 / 0.55 kwh
BRL-01 / 0.75 kwh

CODE: BRL-01

Feeding Hoopers Motor

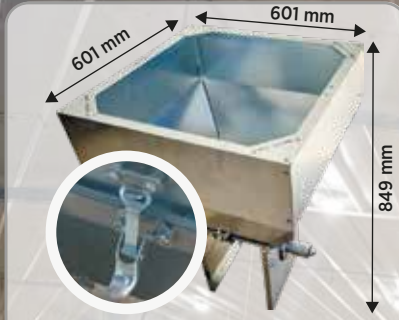

CODE: BRL-02/90

Feeding Hooper

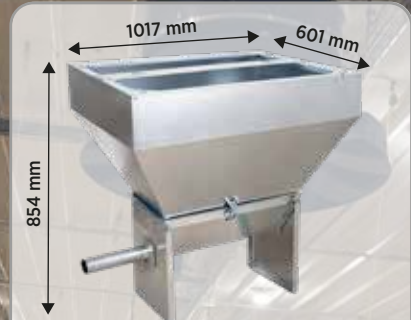

CODE: BRL-02/150

Feeding Hooper

MAXXIPAN

3 Advantages of
Automated Feeding System



Precision Feeding
Uniform Growth



Minimum Wastage
Maximum Profit



Maximum Efficiency
Fast Growth



Big Pan Feeder



CODE: BRL-03

Maxxipan Feeder

- ✓ Extremely strong pan with only 3 main parts.
- ✓ Special feed cutting apparatus can be processed thanks to make it the easiest.
- ✓ 18 birds can feed at a time as against 12 birds in other pans.
- ✓ Easy access for a day old chick with lip height of 3.92 cm
- ✓ Largest Pan, 3 kg storage capacity
- ✓ Bird can not enter into the pan
- ✓ No settings required from the day one upto fully grown up bird



CODE: BRL-04

Pan Feeder



Lenght **300 mm**

Ø **45 x 1.2 mm**

CODE: BRL-05/S

Galvanized Feed Pipe



CODE: BRL-05/01

Feeding Pipe Clamp



Lenght **300 mm**

Ø **45 x 1.2 mm**

CODE: BRL-06/Y

Galvanized Feed Pipe



CODE: BRL-06/01

Round Pipe Clamp



CODE: BRL-07/01

Limit Switch End Line



CODE: BRL-07/02

Feeding Stop Switch



38 mm

CODE: BRL-08

Spiral



CODE: BRL-09

Electronic Sensor



CODE: BRL-09/01

Electronic Sensor
End Line



100
Chickens

CODE: MF-01

Bucket Type Mini Feeder



CODE: MF-02

Suspend Feeder

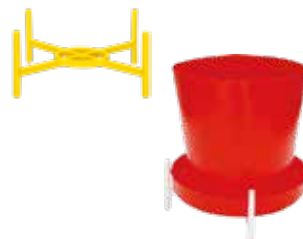

CODE: MF-03

Feeder Stand



CODE: MF-04

Chick Master



20 Kg.

CODE: MF-05

Suspend Feeder



15 Kg.

CODE: MF-06

Suspend Feeder



10 Kg.

CODE: MF-07

Bucket Type Mini Feeder



5 Kg.

CODE: MF-08

Feeder Stand



CODE: NDS-01
Bypass Pressure Regulator



CODE: NDS-02
Sys Max Regulator

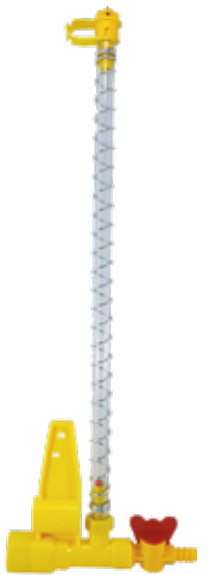

CODE: NDS-03
End-Line Assembly



CODE: NDS-04
Regulator



Ø 20 x 27,2 mm

CODE: NDS-05/G

Galvanized Pipe



360° Flow Pin Stainless Steel





CODE: NDS-05/K

15 pcs Stainless Nipple Line



CODE: NDS-05/P

15 pcs Plastic Nipple Line



CODE: NDS-06

Water Cleaning & Medicating System



CODE: NDS-07

Medicator



CODE: NDS-08

Water Filter



CODE: NDS-09

Stone Water Filter



CODE: NDS-10

Electronic Water Meter



- Features:**
- Plastic body
 - Used for layers
 - Stainless steel inside
 - 70 milliliters per minute
 - 180 degrees

CODE: N-01

Plastic Layer Nipple



- Features:**
- Plastic body
 - Used for broilers
 - Stainless steel inside
 - 70 milliliters per minute
 - 360 degrees

CODE: N-02

Plastic Broiler Nipple



- Features:**
- Main body is made of steel
 - Specially designed for layer chickens.
 - It is mounted by screwing the body.
 - Inside of body is made of stainless steel.
 - 70 milliliters per minute

CODE: N-03

Stain Layer Nipple



- Features:**
- Complete steel
 - Used for broilers
 - Stainless steel inside
 - 80 milliliters per minute
 - 360 degrees

CODE: N-04

Stainless Broiler Nipple



- Features:**
- Plastic and steel body
 - Used for all birds
 - Stainless steel inside
 - 80 milliliters per minute
 - 360 degrees

CODE: N-05

Round Pipe Nipple with Clamp



- Features:**
- Plastic and steel body
 - Used for all birds
 - Stainless steel inside
 - 80 milliliters per minute
 - 360 degrees

CODE: N-06

Square Pipe Nipple with Clamp



- Features:**
- Steel body with rubber gasket
 - Used for layers
 - Stainless steel inside
 - 70 milliliters per minute

CODE: N-07

Inox Nipple with Gasket



- Features:**
- Plastic body
 - Used for broilers, breeders
 - Stainless steel inside
 - 60 milliliters per minute
 - 360 degrees

CODE: N-08

Chubby Nipple with Ball

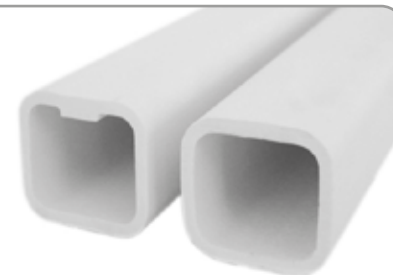

22 x 22 mm

CODE: N-09

Plastic Square Pipe

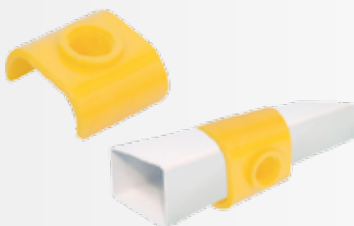

Used with square pipes, helps to install the nipple and remove it without damaging the pipe.

CODE: N-10

Nipple Slot for Square Pipe



Used with round pipes, helps to install the nipple and remove it without damaging the pipe.

CODE: N-11

Nipple Slot for Round Pipe



Ø 27 mm

CODE: N-12

Plastic Round Pipe



CODE: N-13

Plastic Tap With End-Line



CODE: N-14

Flus Tap



CODE: N-15

Square - Circular Reduction



CODE: N-16

Plastic Tap With End-Line



CODE: N-17S

PVC Connected Part



CODE: N-17B

PVC Connected Part



CODE: N-17K

PVC Connected Part



CODE: N-18

Nipple Pipe Hanger



CODE: N-18/01

Nipple Pipe Hanger



CODE: N-19

Nipple Pipe Hanger



CODE: N-20

U Type Nipple Holder



26,7 mm

CODE: N-21

Square Pipe End Line Plastic



CODE: N-22

Electrical Shocker



CODE: N-23

Square Pipe Plastic Connector



CODE: N-24

Round Pipe Plastic Connector



CODE: N-25

Spiral Hose For Line Watering

Capacity
50 Chicks

3 Lt.



CODE: MD-01

3 LT Drinker

Capacity
100 Chicks

6 Lt.



CODE: MD-02

6 LT Drinker



CODE: MD-03

Drinker Stand



CODE: MD-04

Automatic Chick Drinker

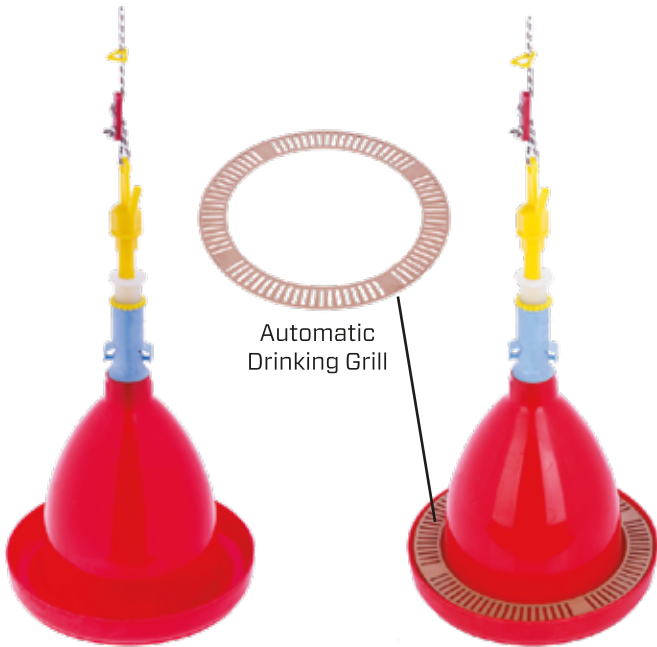

Automatic
Drinking Grill

MD-05

MD-06

CODE: MD-05 / MD-06

Automatic Drinking Pot

Pope	01	←	→
Hose Holder	02	←	→
Pope Adjustment Plastic	03	←	→
Water Pipe	04	←	→

Water Level Adjustment Screw	05	←	→
Water Level Adjustment Nut	06	←	→
Adjustment Screw Spring	07	←	→
Body of the Mechanism	08	←	→
Valve Spiring	09	←	→
Valve Pin	10	←	→
Valve Pin Gasket	11	←	→
Valve Gasket	12	←	→
Valve	13	←	→

CODE: MD-07

Automatic Drinker Mechanism



CODE: N-26

Dish Cup



CODE: N-27

Setting Clips

Ø 21,3 mm



CODE: N-28

"S" Pipe Attach

Ø 26,7 mm



CODE: N-29

"S" Pipe Attach

Ø 30 mm



CODE: N-30

"S" Pipe Attach

Ø 32 mm



CODE: N-31

"S" Pipe Attach

Ø 27 mm



CODE: N-32/K

Nipple Drip Cup

CODE: N-33/Y

Nipple Cup



CODE: N-34

Single Dripcup



CODE: N-35

Square Cup



CODE: N-36

Dual Dripcup



CODE: N-37

Dual Dripcup



CODE: N-38

Dripcup



BROILER & BREEDER VENTILATION SYSTEM

PVC AQUA MAKER Cooling Systems

Cool Poultry House High Efficiency



MODULAR



DURABLE



COOLING EFFECT

CODE: SYS-01

SYS PVC Cooling Pad System



SIMPLE ASSEMBLY

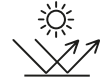

UV PROTECTION



AIRFLOW



AQUAMAKER *Ventilation Systems*

- Easy installation
- Includes an internal water tank, no need for an additional one
- The Floating system enables automatic refill when the water level falls
- Adjustable length and height due to its modular structure
- The pads can be easily installed and uninstalled due to the special lock system
- Includes a drain valve
- PVC materials contain UV
- More durable than alternative cooling systems as it completely made of plastic
- Completely rustproof



Endcover for Deflector



Floating System



Top Bracket



Sprinkling

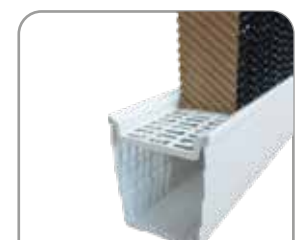

Watergutter

CODE: SYS-02

Pump Unit With Self Filter



- CODE: SYS-02 / 35 hp
- CODE: SYS-02 / 50 hp
- CODE: SYS-02 / 75 hp
- CODE: SYS-02 / 1.0 hp
- CODE: SYS-02 / 1.5 hp

MODEL	QMAX (l/min)	Hmax (m)	Power (P ₁)		Power (P ₂)		Filtering Size (mm)
			kW	HP	kW	HP	
SYS Pump 0.50	195	7	0.37	0.5	0.25	0.33	50
SYS Pump 0.75	255	10	0.55	0.75	0.37	0.5	
SYS Pump 1.00	340	12.5	0.75	1.0	0.55	0.75	63
SYS Pump 1.50	390	17.5	1.1	1.5	0.75	1.0	

V / Hz esp: See pump nameplate. Liquid temperature: 4 °C - 50 °C
Storage temperature: -10 °C - +50 C. Relative Air Humidity: 95% Max.

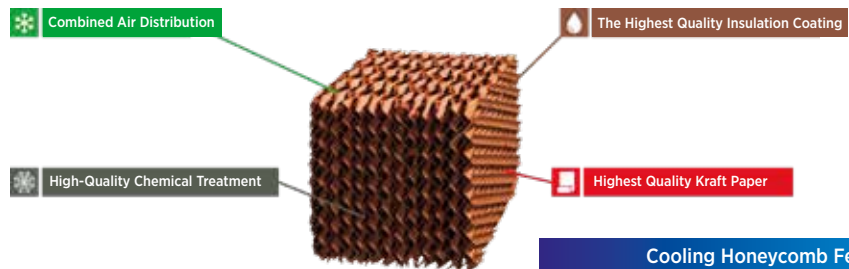
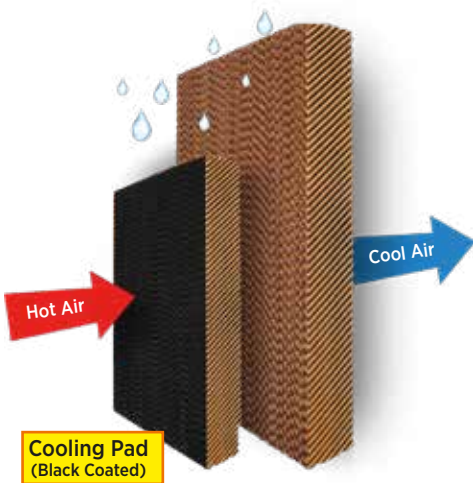

Cooling Pad Dimensions

100x60x10 cm	100x60x15 cm
120x60x10 cm	120x60x15 cm
150x60x10 cm	150x60x15 cm
180x60x10 cm	180x60x15 cm
200x60x10 cm	200x60x15 cm

Cooling Honeycomb Features

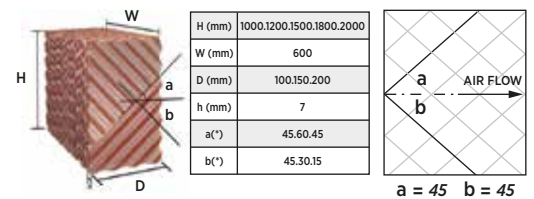

H: Height of the cooling honeycomb
W: Cooling honeycomb width
D: Cooling honeycomb thickness
h: Gutter height
a and b: Gatter angle

Suitable for application conditions where there is a good balance between humidification efficiency and pressure drop

CODE: SYS-03/S

Evaporative Cooling System (Black Coated)

CODE: SYS-03

Evaporative Cooling System

PVC Tunnel Door System



CODE: SYS-05

Cooling Pad Window System

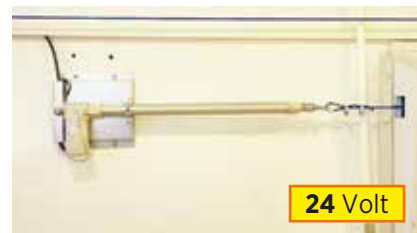

24 Volt

- CODE: SYS-06 / 30
- CODE: SYS-06 / 50
- CODE: SYS-06 / 60

CODE: SYS-06

Window and Air Inlet Motor Actuator

BROILER & BREEDER VENTILATION SYSTEM

Exhaust Fan Shutters
Exhaust Fans

SYS PVC Plastic Exhaust Fan Shutter



- Made of plastic louvers with long life
- Instead of centrifugal system, opening with air power
- Less maintenance cost
- Easy cleaning feature
- **Dimensions 138 x 138 cm.**

CODE: SYS - 138



SYS PVC Plastic Exhaust Fan Shutter



- Ready-to-install with no assembly required
- Shutter sizes to fit all your fans.
- PVC shutters are extremely affordable, durable, lightweight and open easily for minimal airflow resistance
- PVC shutters offer a visually attractive appearance and are corrosion resistant.
- Heavy duty 'SW' PVC shutters can be manual operated.
- **Dimensions 95 x 95 cm.**

CODE: SYS - 98



- High airflow and high efficiency
- Low power consumption, results in lower energy cost
- Direct drive system
- Improves indoor air quality by preventing air stratification and condensation
- Fast and easy installation
- The new SYS18HE and SYS24HE fans belong to the new generation of high energy efficient, very robust and reliable air blower fan range, suitable for an extensive variety of professional applications in order to create the optimal indoor climate.

MODEL	DIMENSIONS	WEIGHT	MOTORPOWER	CAPACITY
SYS18	65x65x55 cm	18 kg	0,33 hp	5.046 m ³ /h
SYS24	80x80x55 cm	24 kg	0,50 hp	10.087 m ³ /h

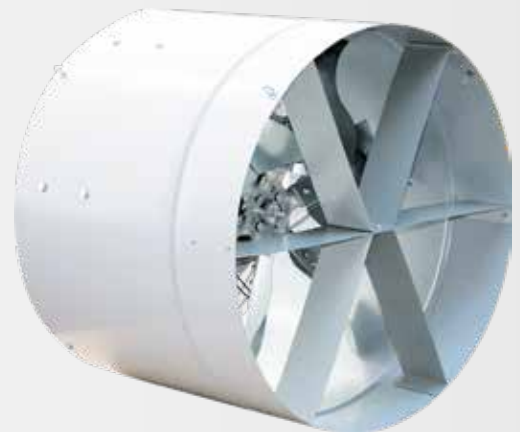

CODE: SYS-18/24

CODE: SYS-18/5 Circulation Fan



- Fan housing and venturi made of the corrosion resistant material Sistemtav Protect
- Central hub and v-belt pulley are made from die-cast aluminium, with reinforced ribs for prolonged lifetime
- Reduced stress on motor bearings
- Welded wire guards designed for easy maintenance fitted with noise reduction supports
- Patented centrifugal system permits an energy efficient solution
- Shutter bearings are maintenance free

DIMENSIONS	WEIGHT	MOTORPOWER	CAPACITY	
			0 Pa	25 Pa
138x138x53 cm	86 kg	1.50 hp	42.125 m ³ /h	38.048 m ³ /h

SYS-50 / SYS-140 Exhaust Fan



- Direct drive system
- Fan housing and Venturi made of strong galvanised sheet-steel
- Shutters are made of pressed galvanised steel in order to ensure highest strength
- Low power consumption
- High airflow capacity with excellent energy efficiency
- The shutter blades are installed on the outlet side, and the whole shutter system is driven by the patented shutter-opening device, that is operated by the propeller rotation.

DIMENSIONS	WEIGHT	MOTORPOWER	CAPACITY	
			0 Pa	25 Pa
95x95x52 cm	60 kg	0.50 hp	14.146 m ³ /h	12.663 m ³ /h

SYS-30 / SYS-100 Exhaust Fan

- Direct drive system
- Fan housing and Venturi made of strong galvanised sheet-steel
- Shutters are made of pressed galvanised steel in order to ensure highest strength
- Low power consumption
- High airflow capacity with excellent energy efficiency
- The shutter blades are installed on the outlet side, and the whole shutter system is driven by the patented shutter-opening device, that is operated by the propeller rotation.

DIMENSIONS	WEIGHT	MOTORPOWER	CAPACITY	
			0 Pa	25 Pa
142x142x129 cm	112 kg	2.00 hp	49.500 m ³ /h	44.700 m ³ /h

SYS-52 / SYS-140/K Exhaust Fan

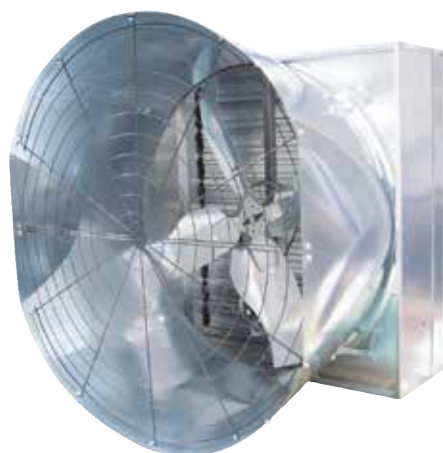



CODE: SYS-07

- Easy operation with color touch screen
- Minimum ventilation depending on the number of animals, fan capacity, daily requirement with daily program
- External temperature, humidity-dependent ventilation
- 3 different ventilation index (Minimum, Transition, Tunnel)
- 2 different season index (Summer, Winter)
- Speed controlled minimum or tunnel ventilation
- Recording of historical failures with reporting
- Recording the operating time of the historical heat and humidity heater
- Controlling the pump according to temperature, outdoor temperature, humidity and time
- Proportional curtain control as required
- Ventilation according to the average of sensor 1, sensor 2, sensor 3, sensor 4 or all
- 2 different lighting program outputs
- Easy setup with user-specific parameter recording
- Ability to send messages to mobile phone
- Remote computer connection with internet tracking and information update feature

- 7" Touch screen
- 3 Pieces internal sensor
- 1 Piece of external sensor
- 1 Piece roof intermediate sensor
- 1 Piece co2 sensor
- 1 Piece moisture sensor
- 20 Control to fans

- Remote access
- Regional or average heating
- Timing and pressure usage flaps
- Optimum and soft transitive air conditioning control
- 45 Day package programs and selectable changes
- Lamp control
- Feed control



CODE: SYS-08



CODE: SYS-09

- 12" Touch wide screen
- 6 Pieces internal sensor
- 1 Piece of external sensor
- 1 Piece roof intermediate sensor
- 1 Piece co2 sensor
- 1 Piece moisture sensor
- 1 Piece air quality sensor
- Pad and pad cover control
- Water report and recording system
- 24 Control to fans
- Remote access
- Regional or average heating
- Timing and pressure usage flaps
- Optimum soft transitive air conditioning control
- 45 Day package programs and selectable change
- Lamp control
- Feed control
- Reporting and graphics



CODE: SYS-10

Humidity Sensor



CODE: SYS-11

Pressure Sensor



CODE: SYS-12

Carbon Dioxide Sensor



CODE: SYS-13

Heat Sensor



CODE: VD-01 100 x 100 x 11.5 cm

Light Traps for 100x100 Exhaust Fan

CODE: VD-02 140 x 140 x 11.5 cm

Light Traps for 140x140 Exhaust Fan



CODE: VD-03

Light Traps for Air Inlet

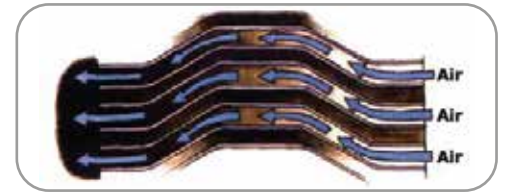
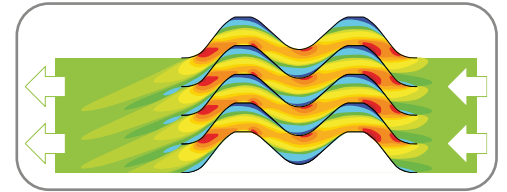
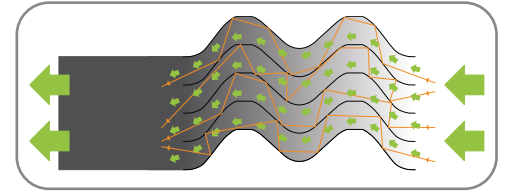
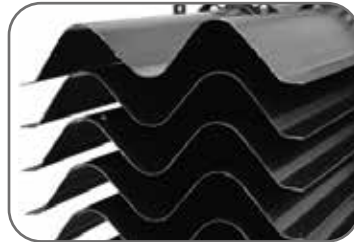

- Can be manufactured at any dimensions.
- Used for Exhaust Fans, Minimum Fans, Chimney Fans, Flap and Hoods.
- Stops light from entering the poultry house from the ventilation system components.
- Ensures an environment of total darkness in the poultry house.
- Easy to mount.
- Contains plastic blades in a durable galvanised frame.

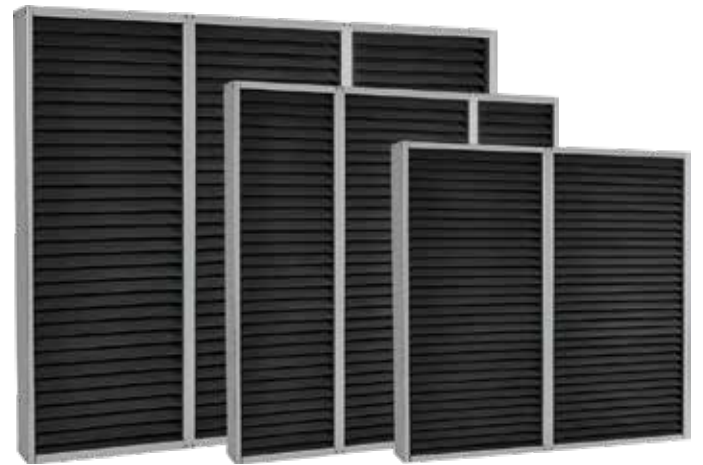

CODE: VS-01

Air Inlet



CODE: VS-02

Air Inlet Storm Hood



CODE: SYS-VS 03 / 15

CODE: SYS-VS 03 / 30

CODE: SYS-VS 03 / 50

CODE: VS-03

Air Inlet Activator Motor

The Breath of Your Poultry House

NEW DESIGN



3 Pully System

Airnest

- Between 0-40 pascal, 1400-3000 m3/hour
- It is made of original ABS material. It is itself an insulation material due to its nature.
- Clacks are controlled by a central system by means of a manual or an engine-driven crane.
- High level insulation
- Robust and light material
- Easy assembly
- Control of air flow direction
- Resistant against chemical and acidic medium

CAPACITY	10Pa	20Pa	40Pa
	1350	1960	2900

CODE: VS-04

AIRNEST

Benefits

1. Made from superior engineering plastic, air inlet anti-UV, anti-aging, and long lasting.
2. The use of a reasonably designed protective net helps prevent birds and insects.
3. With a 20 mm polystyrene insulation board filled inside, the air inlet effectively prevents heat dissipation in winter.
4. The patented pull is easy to open and close because rolling friction cusses low friction.
5. The reset spring made of quality stainless steel is durable and rust resistant.
6. The air inlet features air deflector for more reasonable ventilation.

Air Net Advantages

1. Made of plastic injection molding, high strength, high toughness.
2. With UV resistant additive, air inelt has stronger anit-ageing ability, longer service life, better sealing, flexible opening, with anti-bird net.
3. Double springs ensure excellent sealing.
4. Can be controlled by manual winch or automatic winch.

AIRNEST

Ultrasonically welded insulated cover



Cold and heat resistant raw material



Special design spring system



Air routing



Curved special cover that directs air



Thanks to router pulley minimum friction



Rear grille with whole body



60 cm



26.5 cm

53.5 cm

33 cm



Plastic (ABS) support profile



Internal Dimensions Lenght 53,5 cm Height 26,5 cm

External Dimensions Lenght 60 cm Height 33 cm



CODE: SFW-01

Electronical Weigher System

- Automatic tank weighing system.
- Tank capacity 350-400kg. Can be optionally increased.
- The bait is weighed at the top, then transferred to the bottom with the automatic bottom cover.
- Feed bottom depot is transported to the desired place.
- Precise weighing range
- Easy transport saving time and workmanship done by feeding roperly.
- Easy to use and language options.
- Graphical display showing system flow and weighing
- Economical model with double outlet for twin and side buildings
- Transport feed can be up to 14 stations.

Bird Weighing System

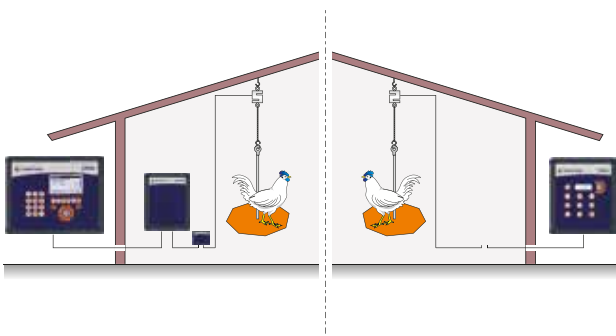

CODE: SFW-02

Bird Scale

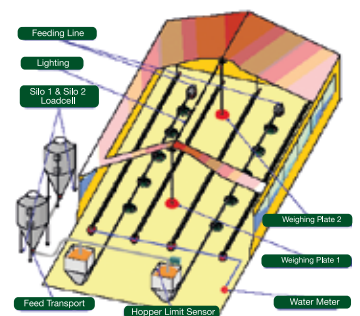

Silo and Feed Transfer System



CODE: SF-01

Galvanized Silo System

GALVANIZED FEED SILOS

CODE	DIAMETER	HEIGHT	CAPACITY	CAPACITY	LEGS
SFL-01	Ø 2.10 m	5.20 m	5.000 kg	8 m ³	4
SFL-02	Ø 2.10 m	5.20 m	7.000 kg	11 m ³	4
SFL-03	Ø 2.10 m	6.00 m	9.000 kg	14 m ³	4
SFL-04	Ø 2.65 m	5.50 m	11.000 kg	17 m ³	6
SFL-05	Ø 2.65 m	6.30 m	14.000 kg	22 m ³	6
SFL-06	Ø 2.65 m	7.20 m	18.000 kg	28 m ³	6
SFL-07	Ø 2.65 m	8.00 m	21.000 kg	33 m ³	6
SFL-08	Ø 2.90 m	8.85 m	25.000 kg	39 m ³	6

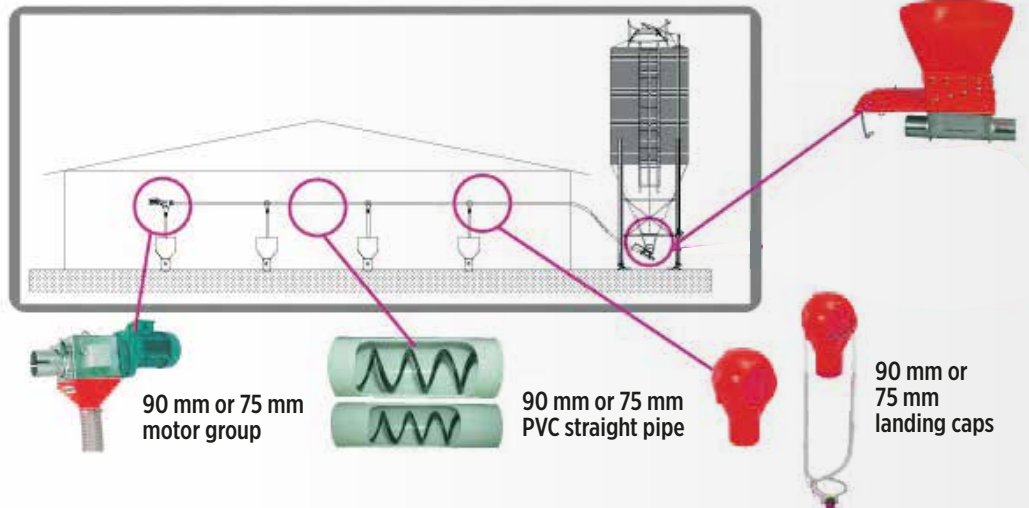

CODE: SF-02

Silo Loadcell Weighing System





The diameter is 36.5 cm. The pans are calculated based on the male inside the house. The pans can be installed to conduits with distances of 100 cm, 120 cm, 150 cm or 200 cm based on the number of male.

CODE: MFS-01

SYS Ross



- Feeding of male is done manually
- Installation and use are simple
- The system is efd above and lowered using a crane, allowing the male to reach the same food at the same time.
- It can be produced in the most suitable form and size up to 3 meters long.
- 1.2 mm galvanized sheet with high corrosion resistance is used.
- It provides a straight line by combining the feed channel and male line cap.

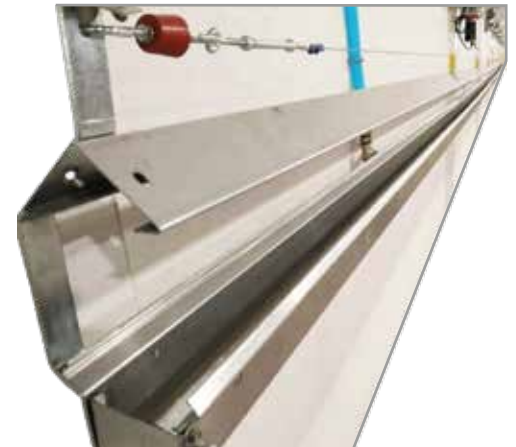
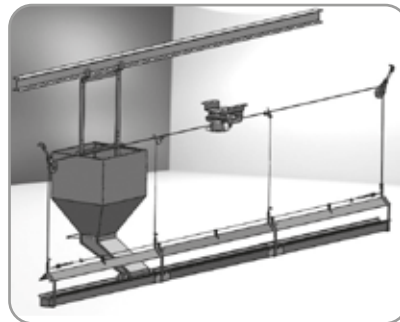

CODE: MFS-01

Manual Male Feeding

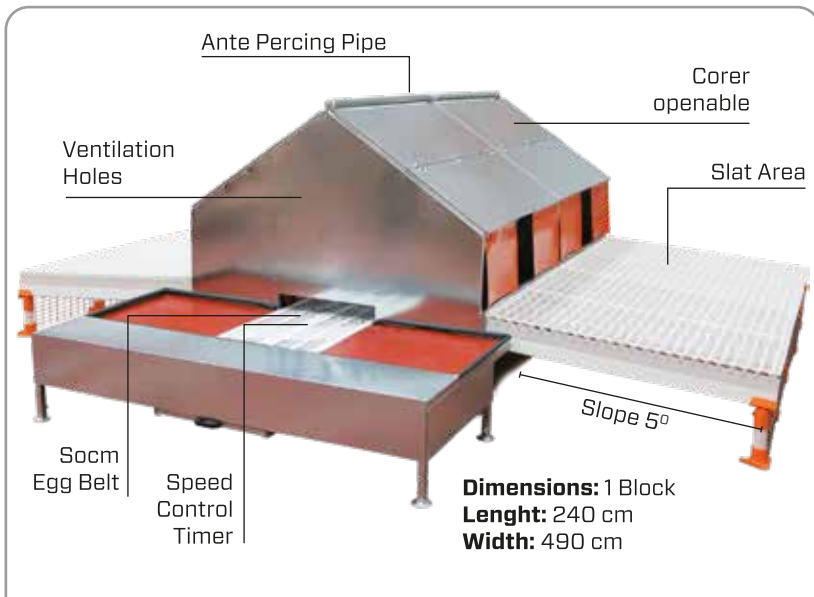

CODE: SMN-01

Egg Collection Center (Automatic Nest)

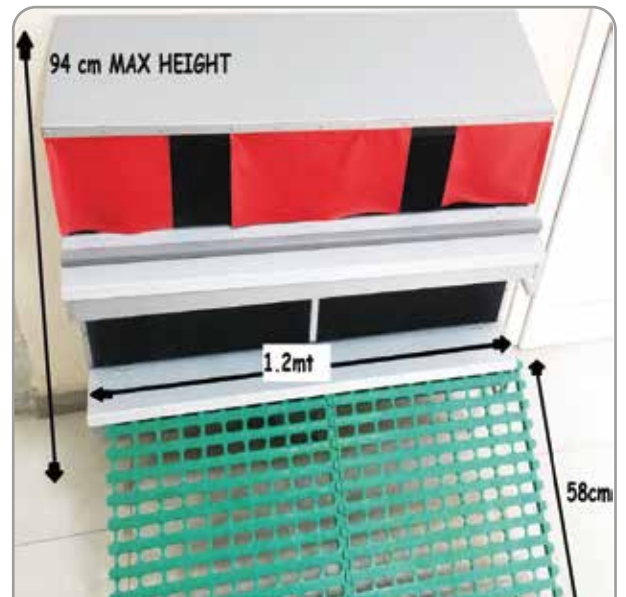

CODE: SMN-02

Manual NEST

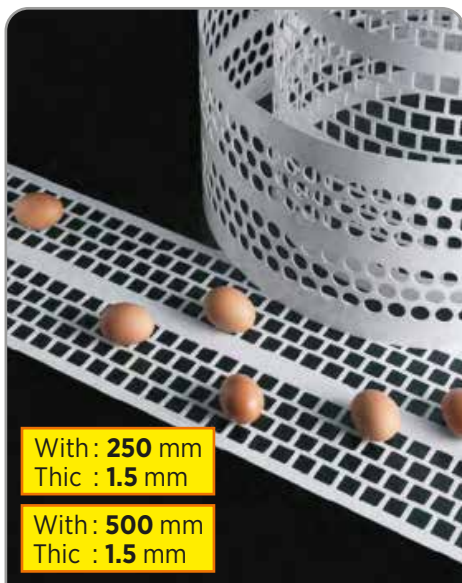

CODE: AN-02

Automatic Nest Egg Transport Belt

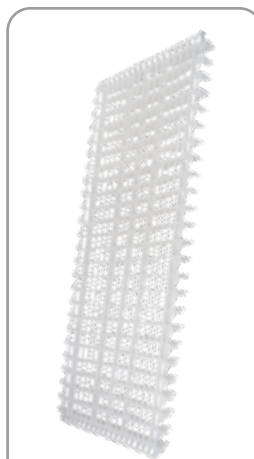

3.7 kg

120 x 60 cm

CODE: AN-01

Automatic Nest Slat

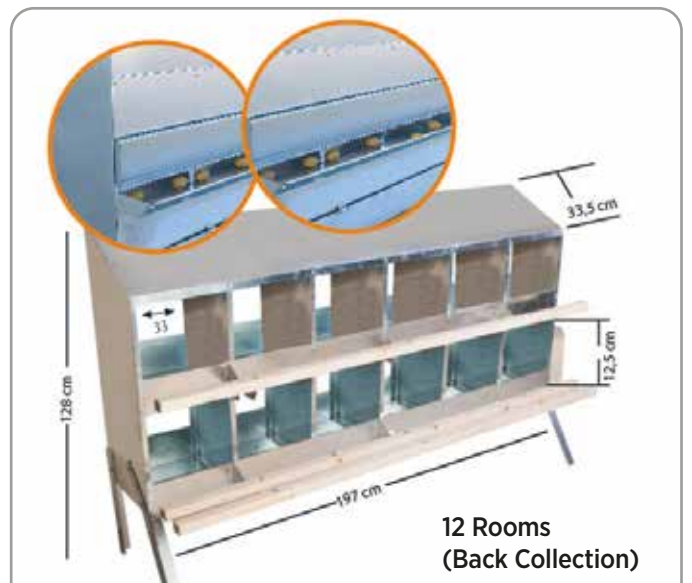

CODE: MN-01

Manuel Nest



CODE: SN-01

Rubber Nestpad



CODE: SN-02

Plastic Nestpad



CODE: SN-03

Rubber Nestpad



CODE: SCF-01

Feeding Trough



CODE: SCF-02

Hanging Wire



CODE: SCF-03

Suspended Channel Bridge

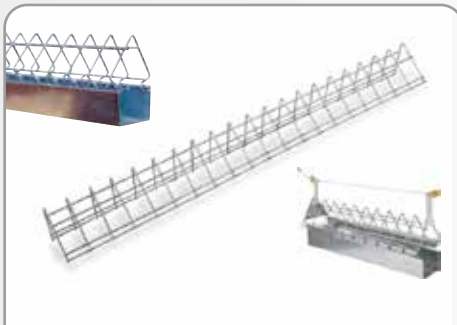

CODE: SCF-04

Standard Channel Grill

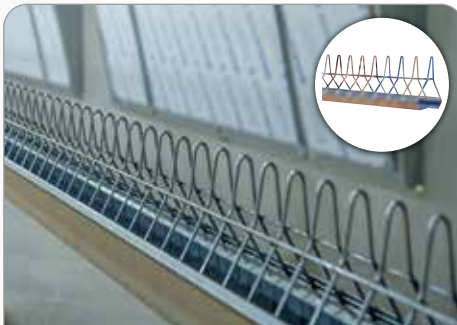

CODE: SCF-05

High Profile Grill



CODE: SCF-06

Suspended Channel Bridge

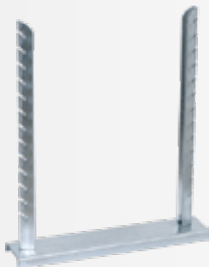

CODE: SCF-07

Chain Feeding Corner Trough Leg



CODE: SCF-08

Chain Feeding Trough Leg



CODE: SCF-09

Motor Gear

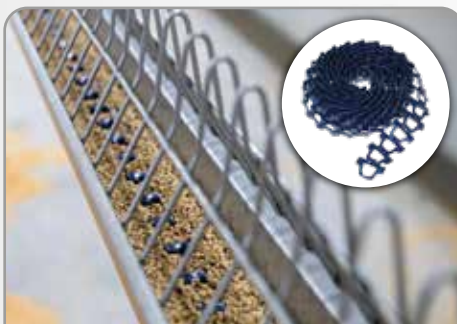

CODE: SCF-10

Feeder Chain

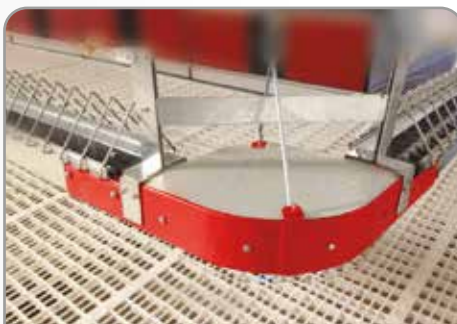

CODE: SCF-11

Suspended Corner



CODE: SCF-12

Corner



CODE: SCF-13
Chain Stetchining Winch



CODE: SCF-14
Feed Hopper



CODE: SCF-15
Chain Feeding Cleaner



CODE: SCF-16
Chain Feeding Motor Drive Unit

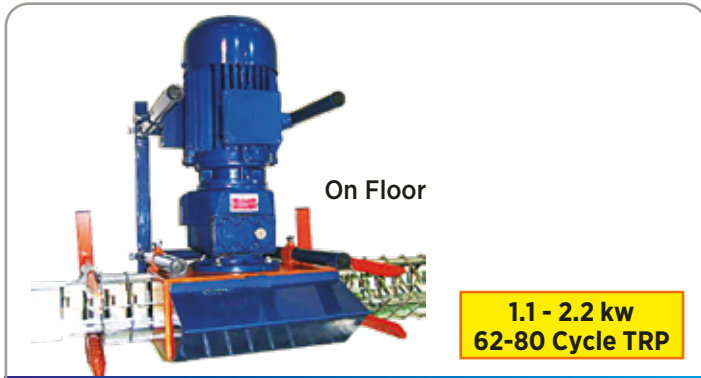

On Floor
1.1 - 2.2 kw
62-80 Cycle TRP
CODE: SCF-17
Chain Feeding Motor Drive Unit



Floor Feeding System

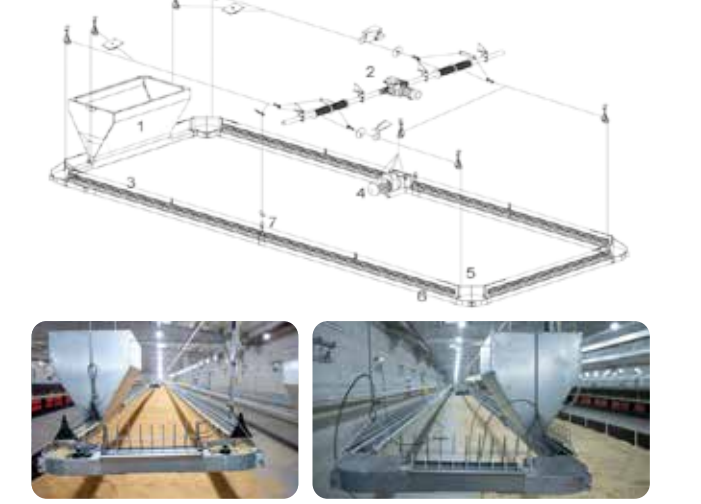

Suspended Model Chain Feeding System

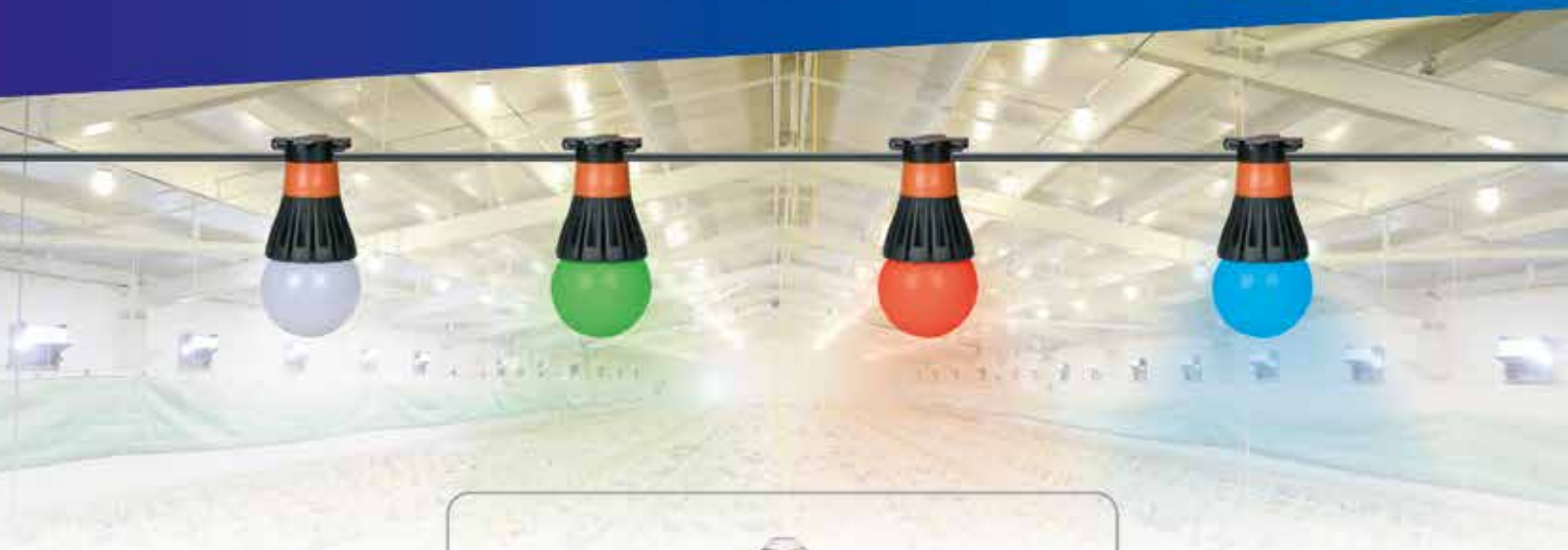

806 lm **9 w**

CODE: SYS PLS-01

LED Lamp



2 x 2.5

CODE: SYS PLS-03

Electric Cable



CODE: SYS PLS-04

Light Holder





CODE: SHS-01

Infrared Heater

- High heat and high efficiency.
- Stainless steel.
- Optimal heating system for the house environment.
- Possibility of manual or automatic control
- It saves fuel because it reflects the temperature on the floor.
- There is no temperature difference in the house.
- Does not require electricity.
- Heater can be adjusted thermostatically or manually.
- Regular cleaning of the filter is recommended for perfect combustion.

CAPACITY	CONSUMPTION	WEIGHT	PRESSURE (MBAR)
500-5.000	36-360	1.5	20-1.400



CODE: SHS-02

Diesel Heater

CAPACITY	CONSUMPTION M ³	HEAT SPACE M ²	DIMENSIONS	WEIGHT
50.000	5 m ³ /s	500 - 2.000	46x100x33 cm	21
80.000	8 m ³ /s	800 - 3.000	46x60x147 cm	40
110.000	10 m ³ /s	1.000 - 4.000	63x154x75 cm	68

Gas Heaters

CAPACITY	CONSUMPTION M ³	HEAT SPACE M ²	DIMENSIONS	WEIGHT
50.000	5 m ³ /s	400 - 2.500	35x42x100 cm	21
80.000	10.5 m ³ /s	1.000 - 3.000	59x52x120 cm	40
110.000	13.3 m ³ /s	1.500 - 5.000	69x58x148 cm	52

Dual Heaters (Natural Gas - Diesel Heater)

CAPACITY	CONSUMPTION M ³	HEAT SPACE M ²	DIMENSIONS	WEIGHT
100.000	10 lt/h - 12 m ³ /s	1.000 - 4.000	63x154x75 cm	71



CODE: SHS-03

Solid Fuel Heaters
Heat generator (air heater) solid fuel

- Automatic adjustment of fuel supply speed
- Burning chamber is made of cast iron
- Chrome steel mixer has heat resistance up to 1200
- 90% thermal efficiency
- Turbo system

CAPACITY	MOTOR	FAN FLOW M ³ /H	AIR FLOW M ³ /H	CONSUMPTION COAL 5000 KCAL/KG
150.000	2.61	12.000	8.000	13.33 KG
200.000	3.31	12.000	12.000	17.18 KG
250.000	4.11	12.000	12.000	22.22 KG
300.000	5.11	18.000	13.500	26.67 KG
400.000	8.99	27.000	13.500	35.56 KG
500.000	8.99	40.000	26.650	44.44 KG
600.000	8.99	50.000	30.500	58.00 KG



3.000 Kg.

CODE: SA-01

Heavy-duty Ceiling Winch

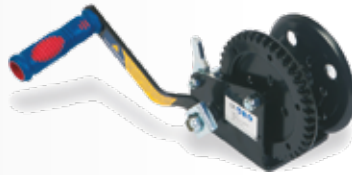

1.200 Kg.

CODE: SA-02

Manuel Wall-Mounted Winder



1.200 Kg.

CODE: SA-03

Blue Ceiling Winch



CODE: SA-04

Feeder Line Lifter

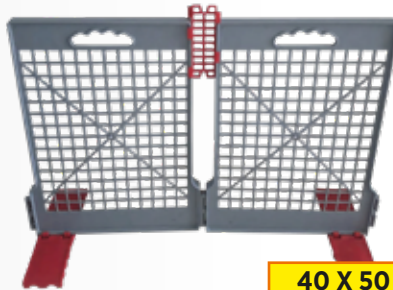

40 X 50

CODE: SA-05

Chick Separator



Ø 80 mm

CODE: SA-06

Plastic Pulley



Ø 80 mm

CODE: SA-07

Plastic Pulley



Ø 60mm

CODE: SA-08

Plastic Pulley



Ø 40 mm

CODE: SA-09

Plastic Pulley



Ø 20 mm

CODE: SA-10

Plastic Pulley



Ø 60mm

CODE: SA-11

Steel Pulley



Ø 50 mm

Ø 80 mm

CODE: SA-12/50 - SA-12/80

Steel Pulley



CODE: SA-13

Wall Winch Connecting Plate



CODE: SA-14

Pulley Hanging Plate



CODE: SA-15

Nipple Rope



Ø 8mm

CODE: SA-16

Polypropylene Rope



- 1,5 mm
- 2 mm
- 3 mm
- 4 mm
- 5 mm
- 6 mm
- 8 mm

Product Galvanized Aircraft Cable

CODE: SA-17

Steel Rope



5/16"

CODE: SA-18

Steel Rope Clamp



5.5mm

2.5mm

CODE: SA-20B / SA-20K

Plastic Rope Clamp



60x34x8 cm

CODE: SA-21

Rubber Disinfection Tank

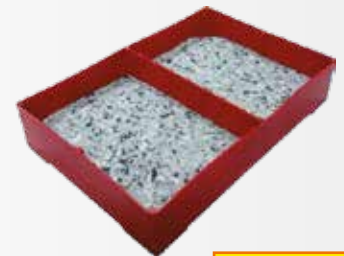

52x35 cm

CODE: SA-22

Plastic Disinfection Tank



CODE: SA-23

Plastic Slats

With Switch and Brake 0.55 kw



CODE: SLS-01

Feeding and Drinking
Line Lifting System

With Switch and Brake 0.75 kw



CODE: SLS-02

Feeding and Drinking
Line Lifting System

TRANSPORT & HANDLING SOLUTIONS

Incubation Equipments



INC-01 16 LEVELS

Dimensions:
160 x 55,8 x h 203 cm
Capacity:
32 Viol

INC-02 14 LEVELS

Dimensions:
160 x 55,8 x h 203 cm
Capacity:
28 Viol

CODE: INC-01 / INC-02

Setter Trolley



Dimensions:
160 x 55,8 cm

Capacity:
32 Baskets

CODE: INC-03

Hatcher Trolley



Dimensions : 59.5 x 39.5 x 16.5 cm
Weight : 1.400 gr
Capacity : 82 Chicks

CODE: INC-04

Setter Tray (82)



Bottom Pierced

Dimensions : 69.5 x 48.5 x 15 cm
Weight : 1.950 gr
Capacity : 100 Chicks

CODE: INC-05

Big Chick Box 2 Compantment

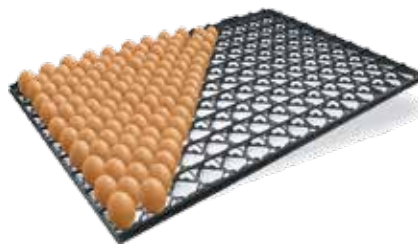

Dimensions : 73.5 x 50.5 x 4 cm
Weight : 1.100 gr
Capacity : 150

CODE: INC-07

Chick Setter Tray



Dimensions : 80 x 56.5 x 14 cm
Weight : 2.580 gr
Capacity : 150

CODE: INC-08

Chick Hatcher Tray



38 x 31 x 5 cm

129 Egg

CODE: INC-09

Quail and Partridge

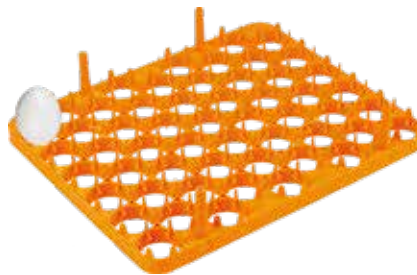

38 x 31 x 7.5 cm

54 Egg

CODE: INC-10

Setter Tray



41 x 34 cm

35 Chicks

CODE: INC-11

Hatcher Basket

Live Bird Transport Systems / Egg



Dimensions : 96 x 57 x 27 cm
 Weight : 8.300 gr
 Capacity : 12 - 16 chicken

CODE: SLC-01

Open Top Crate

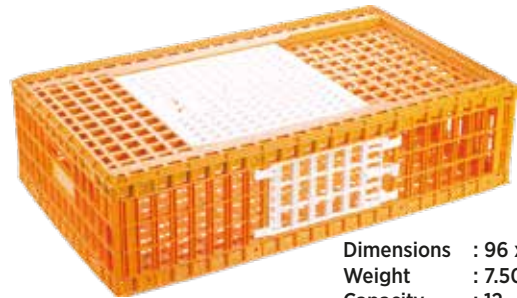

Dimensions : 96 x 57 x 27 cm
 Weight : 7.500 gr
 Capacity : 12 - 16 chicken

CODE: SLC-02

Top and Side Doors Crate



Dimensions : 96 x 57 x 27 cm
 Weight : 7.500 gr
 Capacity : 12 - 16 chicken

CODE: SLC-03

Top and Side Doors Crate

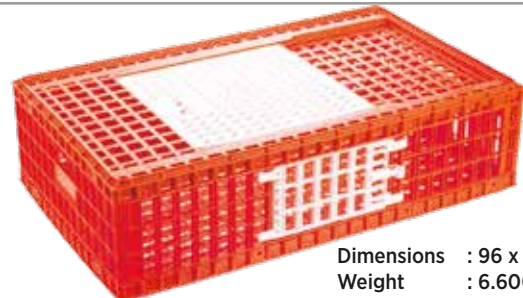

Dimensions : 96 x 57 x 27 cm
 Weight : 6.600 gr
 Capacity : 12 - 16 chicken

CODE: SLC-04

Open Top Crate

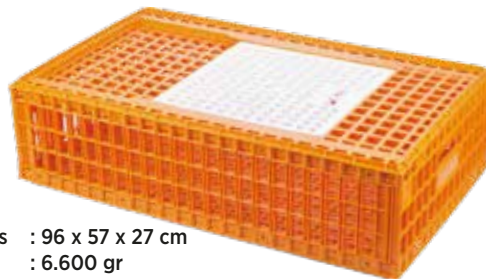

Dimensions : 96 x 57 x 27 cm
 Weight : 6.600 gr
 Capacity : 12 - 16 chicken

CODE: SLC-05

Open Top Crate

Egg Handling

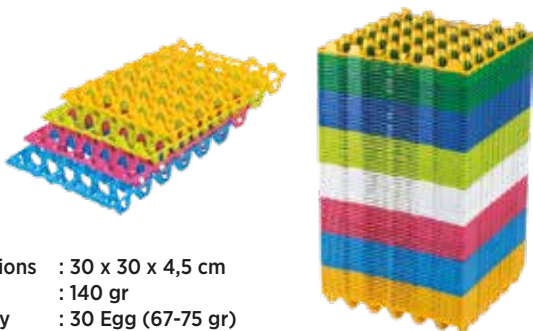

Dimensions : 30 x 30 x 4,5 cm
 Weight : 140 gr
 Capacity : 30 Egg (67-75 gr)

CODE: SLC-06

Plastic Egg Tray



Dimensions : 68 x 37 x 42 cm
 Weight : 3.100 gr

Capacity
 With Shirink : 14 Viol 420 Egg
 Double Shirink : 12 Viol 360 Egg
 Without Shirink : 8 Viol 240 Egg

CODE: SLC-07

Egg Basket



UTC STAV

FOR POULTRY PACKAGING & EQUIPMENT

The Smart Choice...

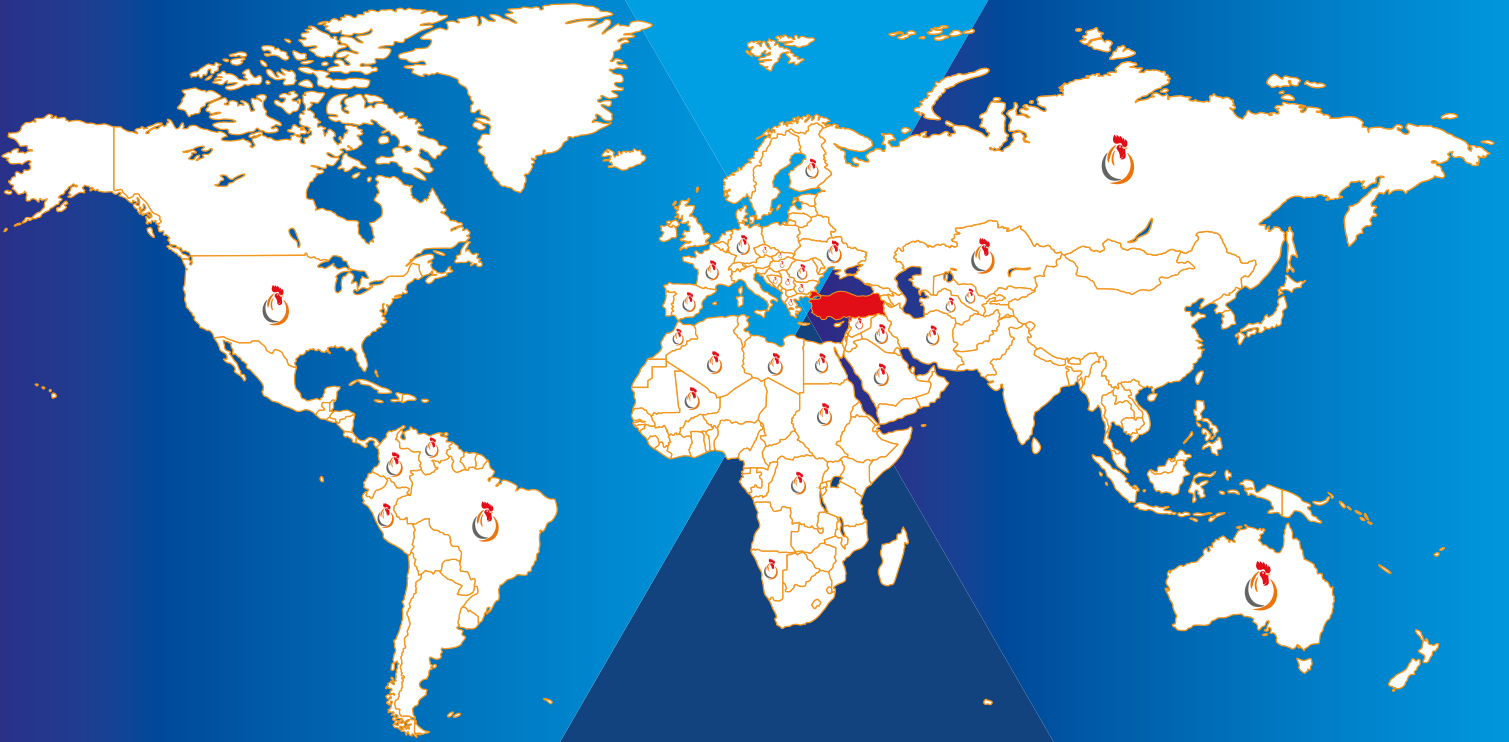

► **Head Office**

İstasyon Mah. Güney Yan Yol Cad.
1456. Sk. No: 54/2 41400
Gebze/Kocaeli

► **Factory**

İstasyon Mah. 1456 Sk. No:4
Gebze - Kocaeli / TÜRKİYE

► **Dubai Office :**

Office C1703-025,
Busines Bay, Dubai , UAE
Tel :+(971) 501686829
License Nr. 1091820
Email : eagleprestige@unelsaid.com

► **Egypt Office:**

119 El nozha st.Helioplies
Cairo, Egypt
Tel : 0020 10 66622100
Email: adel@unelsaid.com

► P +90 262 646 20 18

► info@utcstav.com

► +90 531 221 78 32
► +90 533 017 74 83

►   /Utcstav